

LEFT CHANNEL SHOWN

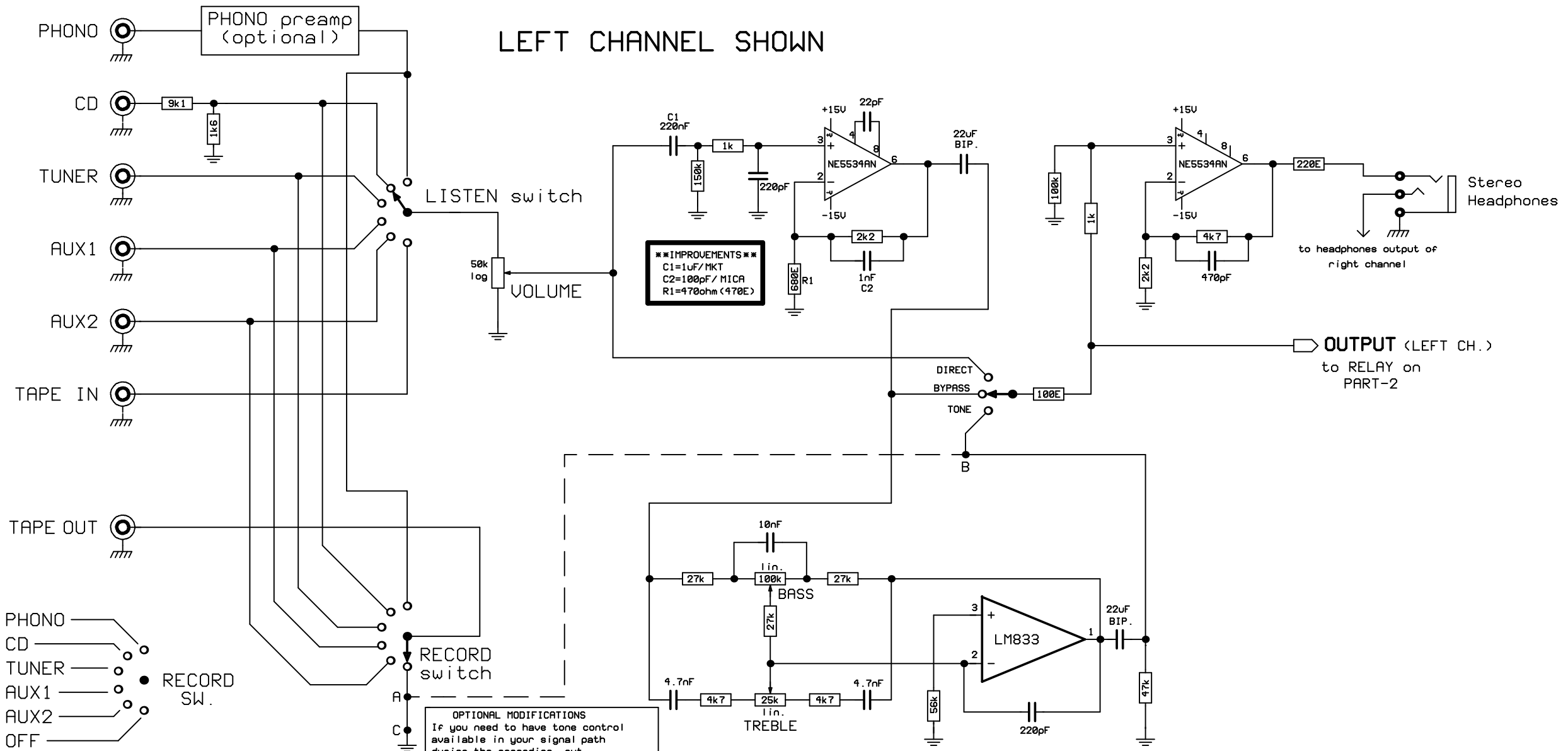

****IMPROVEMENTS****
 C1=1uF/MKT
 C2=100pF/MICA
 R1=470ohm(470E)

OPTIONAL MODIFICATIONS
 If you need to have tone control available in your signal path during the recording, cut connection between A and C and make new connection between points A and B!
 Change accordingly what is written for that position of RECORD switch on the front panel!
 If you do this modification, you will actually have two outputs from preamp one on standard output connector and another on TAPE OUT connector That could be useful for testing two power amplifiers simultaneously.

ALLEGRO
 Designed by Dr. Borivoje Jagodić
<http://bas.elitesecurity.org>

PART-1